

微調搪孔頭

容易調整

- 高精度容易調整 $0.02\text{mm}/\text{div}$ ，游標微調可至 $2\mu\text{m}$

廣泛運用

- 微調搪孔頭，可設計裝置在不同刀具
- 雙階孔安裝容易
- 可與大眾品牌規格互換

結構設計

- 使用彈力結構，沒有背隙
- 使用卡式刀座，尺寸可以更大範圍



5

高速搪刀

微調搪孔頭

加工角度90°

- 使用刀片：CCMT, CCMW, CCGH, CCGT, CCGX, TCMT, TCMW, TCGT, TCGX
- 最大範圍 · 凹槽間隙不可大於扳手尾端寬度

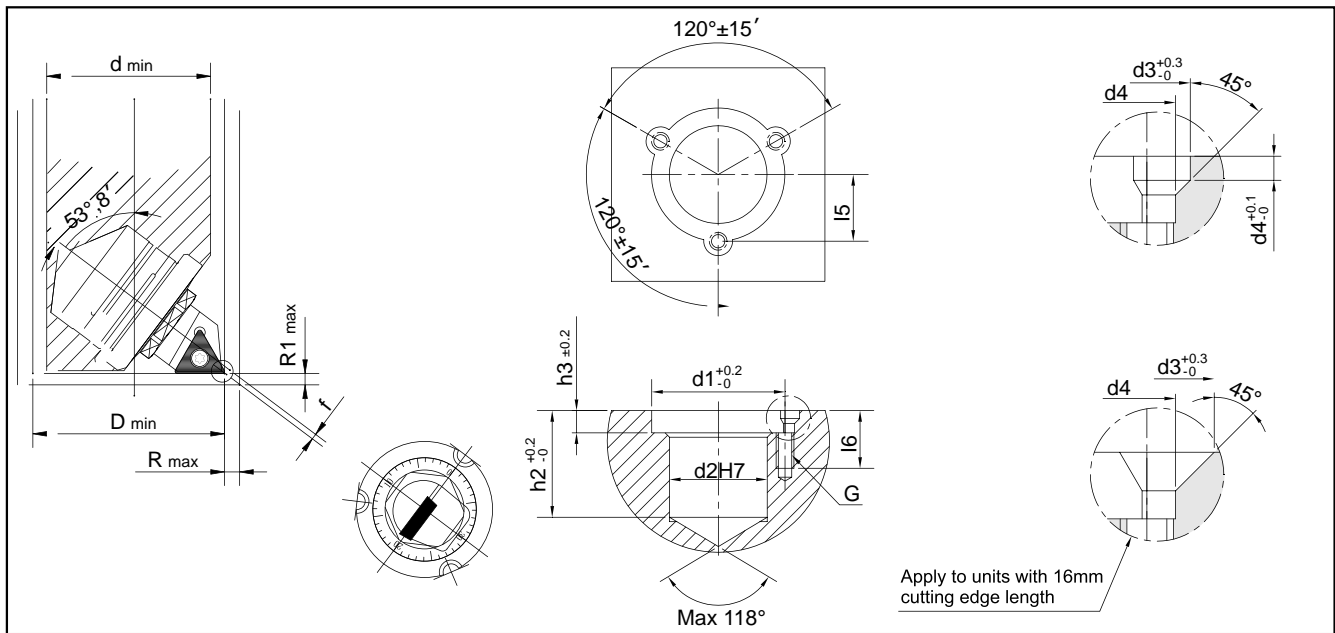

Order No.	Insert Radius	Dimensions / mm							Mounting Dimensions / mm								
		dmin	Dmin	Rmin	R1max	f	h2	h3	h4	d1	d2	d3	d4	G	I6	I5	
99148-3106	0.2	22	25.7	2	1.5	0.40	11.5	2.8	1.6	19	16	4.6	3.2	M3	10	9.65 ±0.02	
	0.4		25.4														0.40
	0.8		24.8														0.45
99148-3209	0.2	28.5	33.4	2.8	2.1	0.95	15.5	4	1.6	25	20	4.6	3.2	M3	10	12.5 ±0.02	
	0.4		33.1														1.0
	0.8		32.5														1.1
99148-3311	0.2	38	42.9	4.8	3.6	1.15	24	5	1.8	30	22	6.5	4.3	M4	15	15.4 ±0.02	
	0.4		42.6														1.2
	0.8		42.0														1.3
99148-3416	0.2	55	60.6	8	6	1.3	33	6.3	-	46	32	11.9	5.4	M5	20	23 ±0.02	
	0.4		60.0														1.4
	1.2		59.4														1.5

設定與夾持零件

Item	Spanner	Mounting Screw	Insert Screw	Mounting Screw Key	Insert Screw Key	Mounting Screw Key
99148-3106	99148-3106-SP	99148-3106H	99148-3106I	NK-T9	NK-T7	-
99148-3209	99148-3209-SP	99148-3209H	99148-3209I	NK-T9	NK-T7	-
99148-3311	99148-3311-SP	99148-3311H	99148-3311I	NK-T15	NK-T7	-
99148-3416	99148-3416-SP	99148-3416H	99148-3416I	-	NK-T15	99148-3146-J

5

高速搪刀



加一個鎖固螺絲，可以增加尺寸調整精度

加強型設計

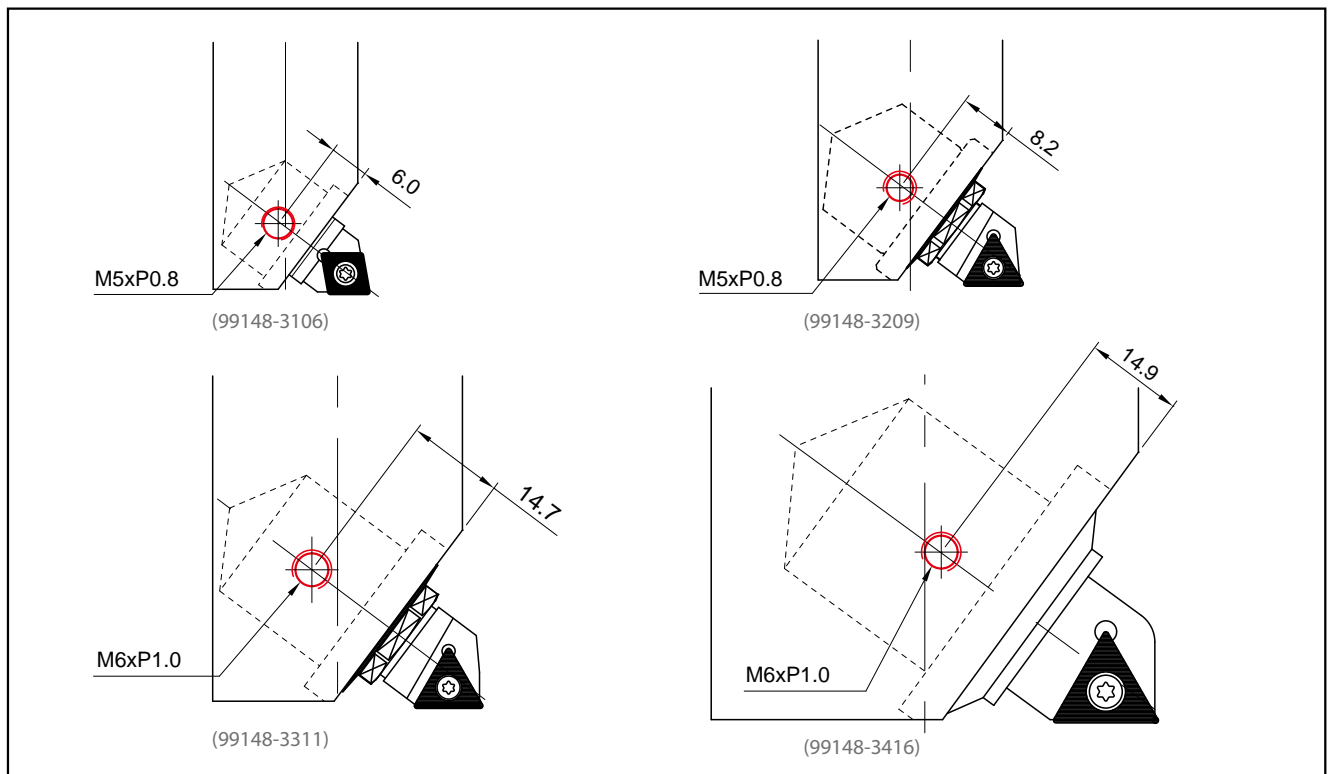

- 在本體側方向增加一個銅頭固定螺絲，可以避免在加工底面時，產生振動
- 使用加強結構後，搪孔更精準
- 可以加長刀片壽命

Set Screw position of boring head



5

高速搪刀

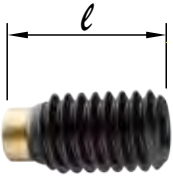
Order No.	MBU Type			Size	
				Illustration	l
NSC-50085	99148-3106		06		8.5
NSC-50085	99148-3209	09			8.5
NSC-60115	99148-3311	11			11.5
NSC-60115	99148-3416	16			11.5